

VARIETY



Technical Rider
(60min)

As Of Dec. 15.
2022

1. Speaker System

- Should be prepared 3way or 4way system and system control by our sound-engineer
- Need good condition sound system like D&B, L-Acoustic, Meyer and etc
- Sub-Woofer should be driven independent Aux-out or Matrix
- Should be large size side fill monitor speaker and front wedge Monitor

2. Mixing Board System

- Good condition Yamaha CL or QL Series
 - (if it is impossible to prepare Yamaha Series)
Midas M32 with stage rack on the stage or multi channel box
- Yamaha O1V96, LS9, Allen&Heath Qu and low grade console, analog console is not allowed

Sound

3. Microphones

wireless	Shure Axient Digital AD2/Beta87 or UR4D+	5ea
wired	Shure SM58	4ea
	Shure SM57	1ea
	DPA4011 or 2011 or Audio Technica AT4051b	2ea

4. Mic Stands : Should be prepared good quality brand and good condition Microphone stand (K&M)

stands	Long Boom Mic Stands	5ea
	Gooseneck Stands	5ea
	Gooseneck Bass	2ea

Sound

5. Input Mic Channel

CH No.	Inst.	Microphone	Stand/Remark
1	Buk WL	Shure Axient beta87	Long
2	Jangu WL	Shure Axient beta87	Long
3	Kkwaengari WL	Shure Axient beta87	Long
4	Jing WL	Shure Axient beta87	Long
5	Taepyeongso WL	Shure Axient beta87	Long
6	Jangu 1 / Jing	Shure sm58	Gooseneck or Short
7	Jangu 2 / Kkwaenggwari	Shure sm58	Gooseneck or Short
8	Jangu 3 / Gung	Shure sm58	Gooseneck or Short
9	Jangu3 / Chae	Shure sm58	Gooseneck or Short
10	Jangu 4 / Jing	Shure sm57	Gooseneck or Short
11	Ambience L	DPA 4011	Gooseneck Bass
12	Ambience R	DPA4011	Gooseneck Bass

- Please prepare good condition wash and spot moving light
- If preparing moving light is difficult, the tower lights must be correctly positioned in the player's position
- The console does not matter which console, but prefer MA or Avolites
- The entire stage white is required, the flag must be clearly illuminated
- Please refer to the link below for the lighting design <https://youtu.be/-9ZbuMPkpxk>

NO	PROGRAM	DIRECTION
1	Munguk, Binari	Enter from the entrance of the audience > Follow the player's position > Full white when coming up to the stage
2	SamdoSuljanggoGarak (Korean drum 4 players)	Oval 4 people on the floor or mat, Flag follow up
3	SamdoNongakGarak (Ensemble)	- Individual top lighting for players : Buk IN -> Buk OUT -> Buk, Kkwaenggwari, Jing (Slowly) - Be located in an oval shape on the upper stage(or individual mats), Flag follow up - Full white on the stage

Stage

1. Flag

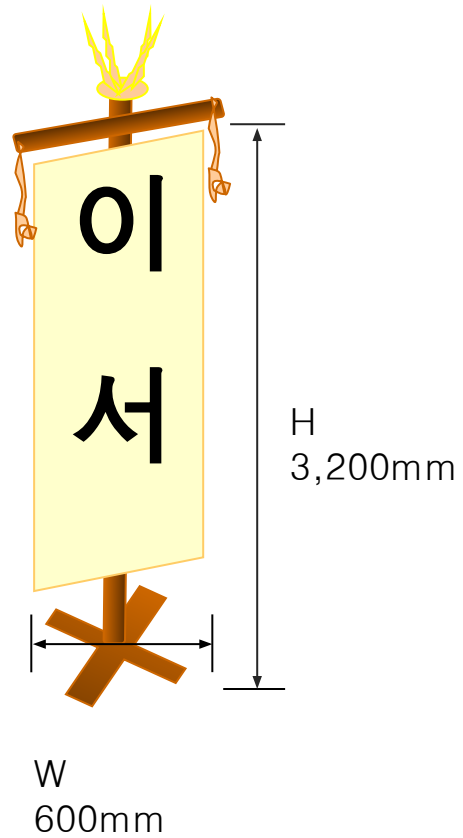

2. Individual Mats or Upper Stage

- Individual Mats (4ea)

W 1,200mm * L 900mm



- Upper Stage

W 10,800mm * L 3,600mm * H 150mm



Stage Plot 1. Munguk, Binari (10min)

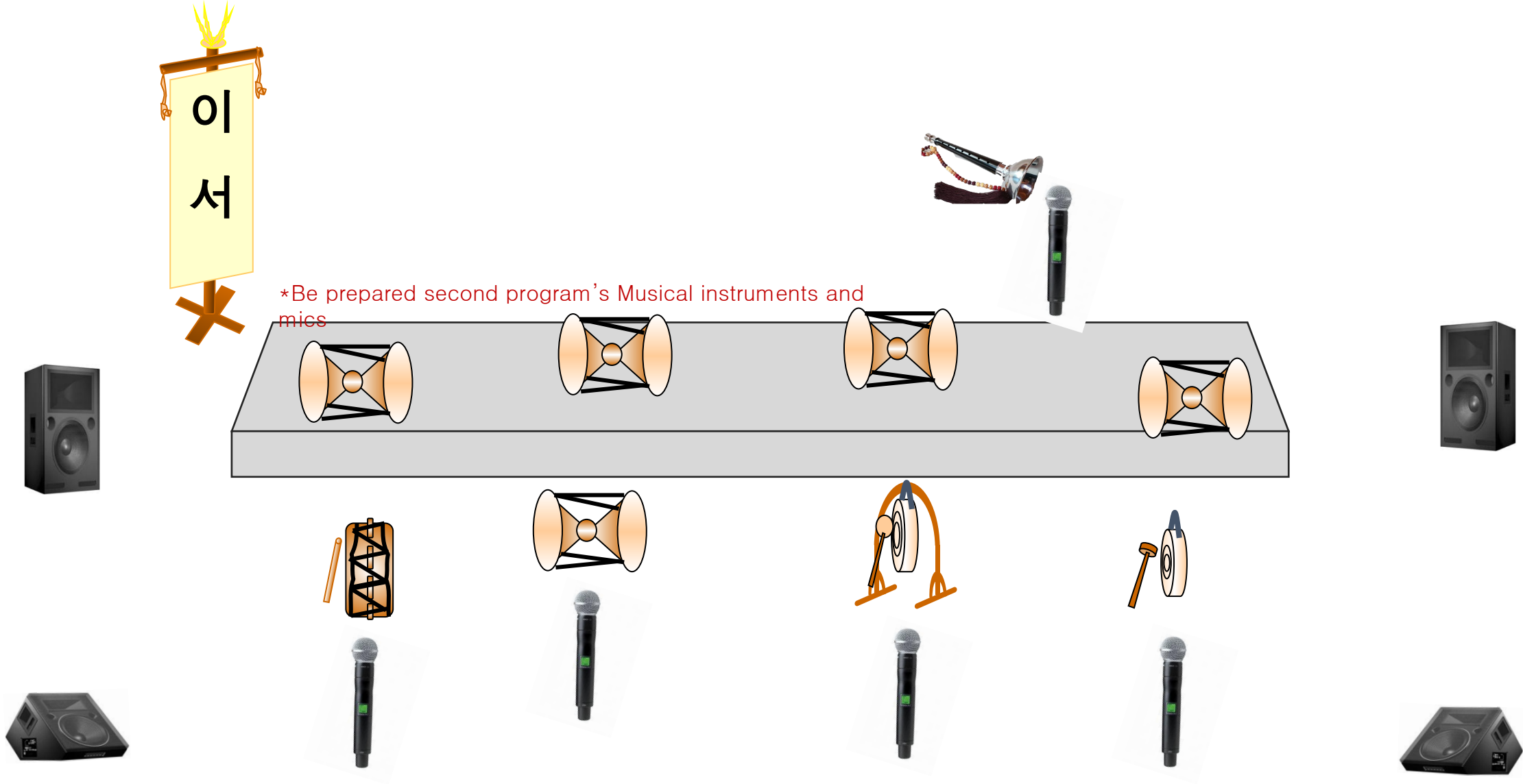

Stage Plot 2. SamdoSuljanggalak (10min)

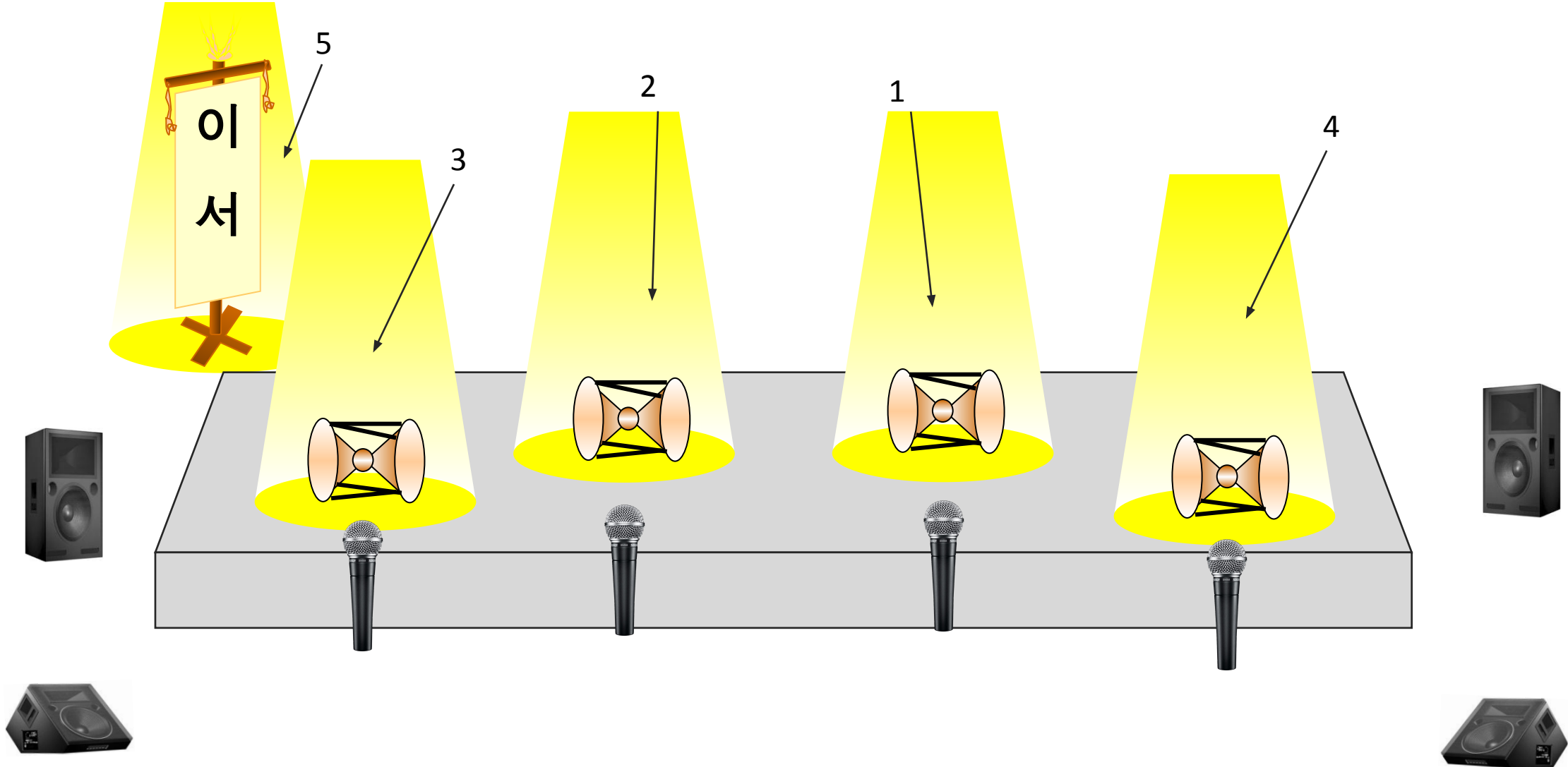

Stage Plot 3. SamdoNongakGarak (10min)

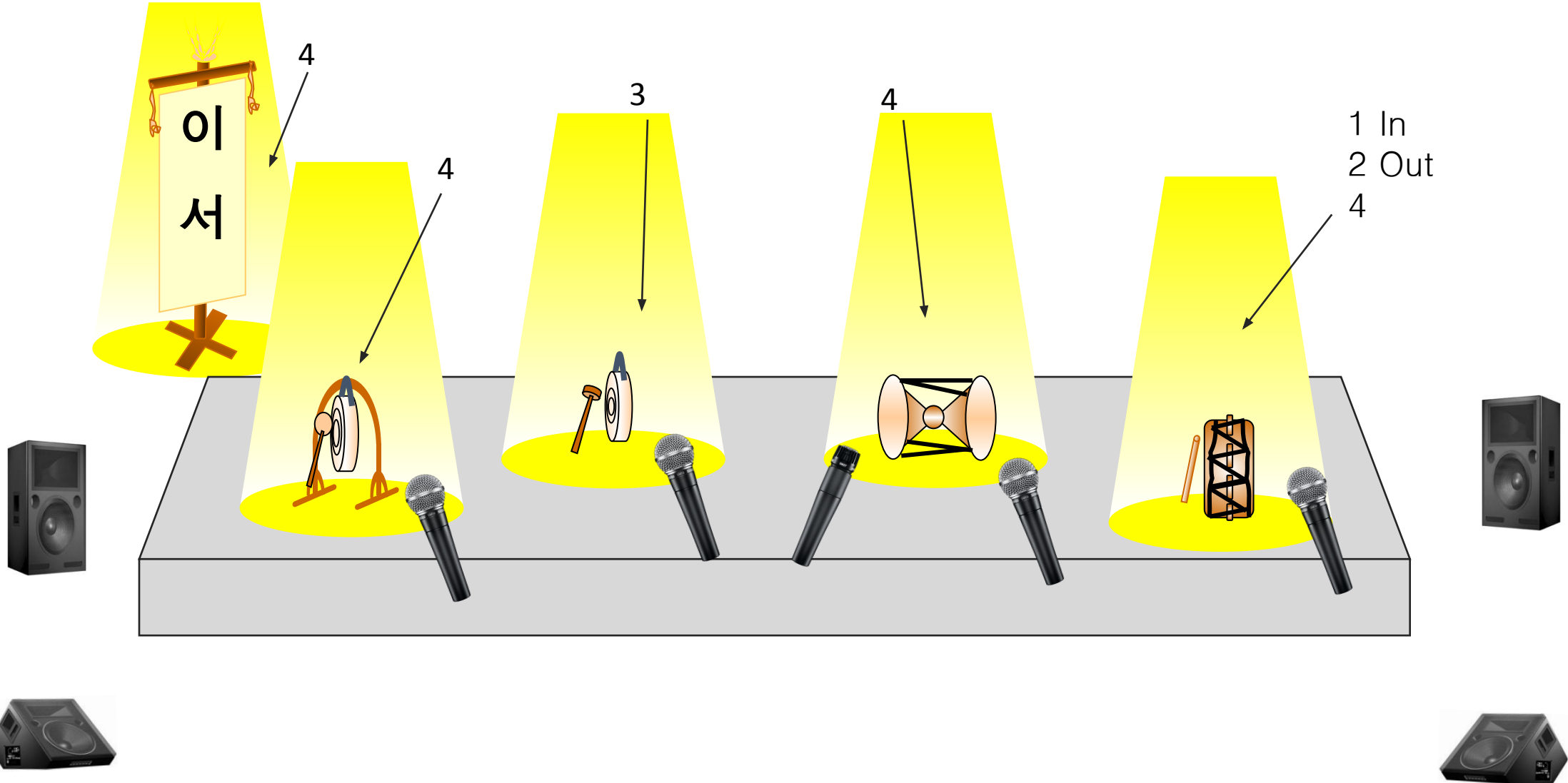

Stage Preset 4. PanGut (25min)

